



長寿命と高速化を両立! コストダウンに貢献!!

◆サイドスルーとは

高効率のクーラント循環を可能にした新しい給油方式のサイドスルー!
タップの冷却性能、切粉排出性能を飛躍的にアップ!

Side-through with a new lubrication system that enables highly efficient coolant circulation!
Dramatically improved tap cooling performance and chip discharge performance!

シャンク部から切削油を通す新構造

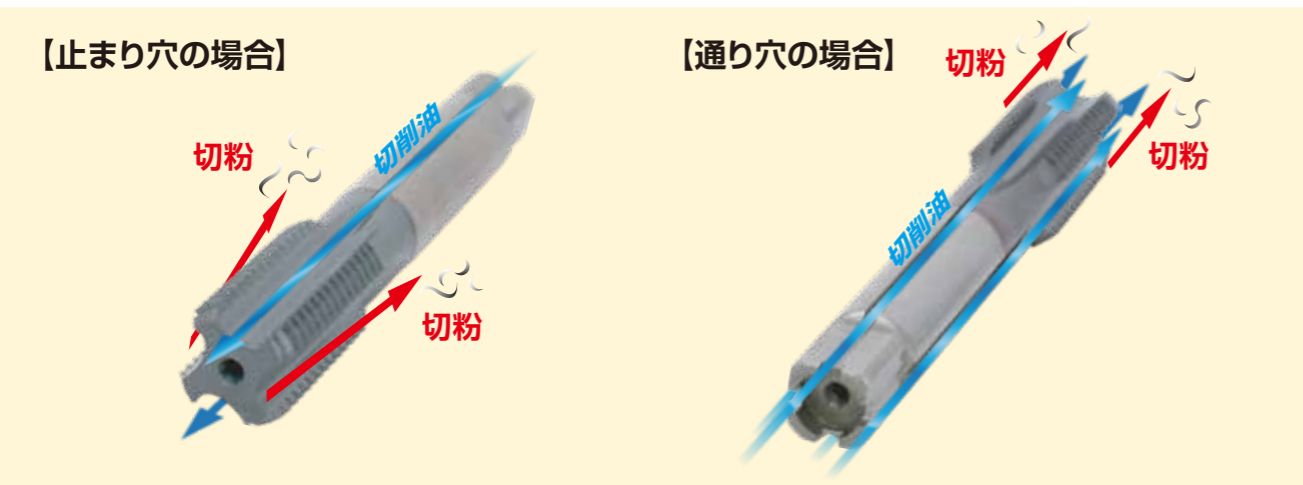

◆ZCとオイルホールの流量比較

サイドスルーなら
MQLでも流量アップが
可能!!

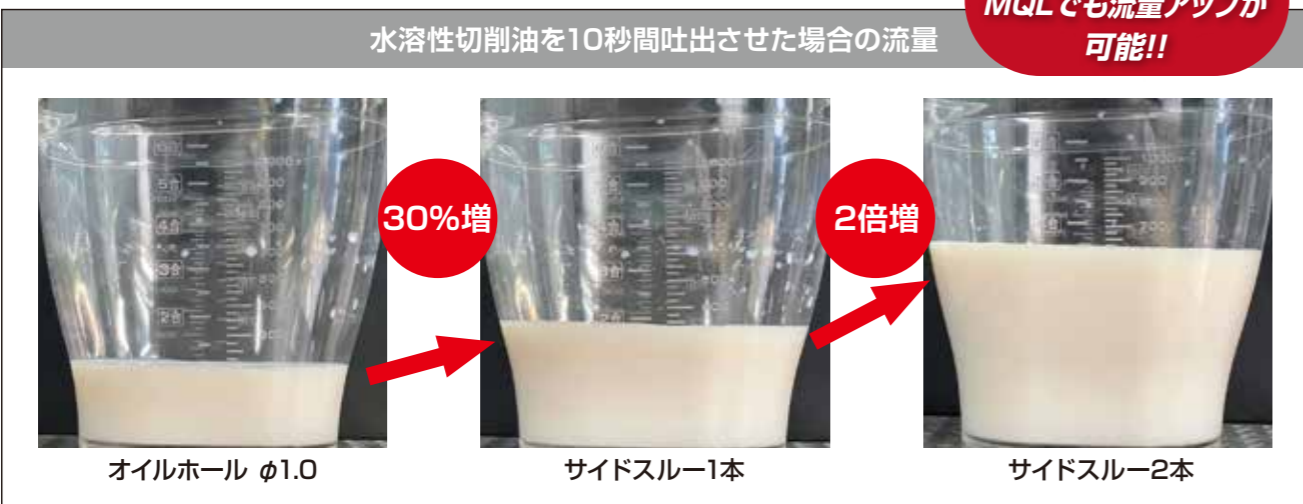

◆ホルダー使用例

※下記以外のホルダーに関してはお問い合わせください

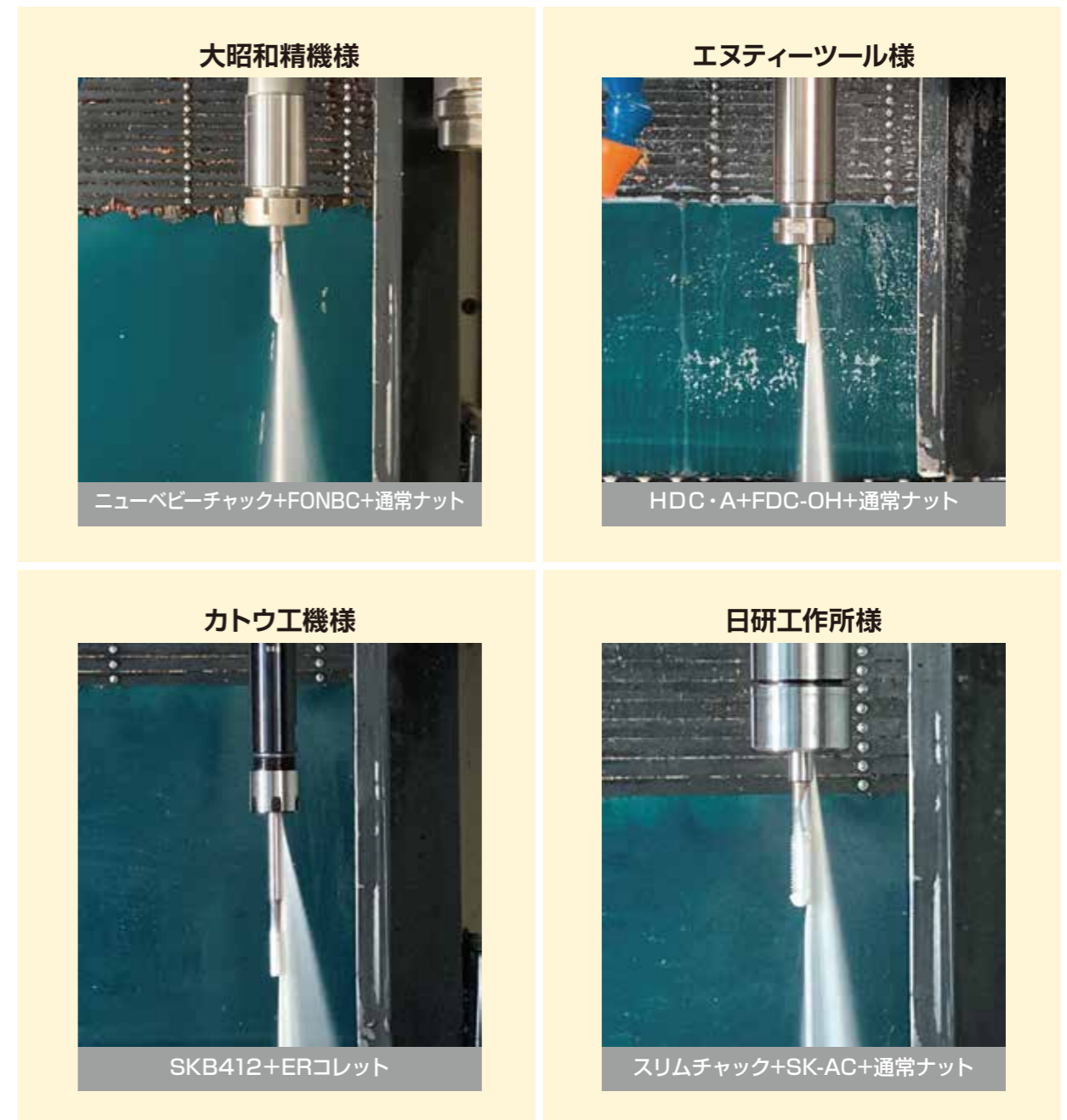

◆使用する上で注意が必要なホルダー

- 下記に該当する場合はお問い合わせください。
- ゴムや樹脂でタップをホールドするモデル
 - 分割数が多い(8分割を超えるもの) スプリングコレット
 - コレットの隙間や端面から吐出するモデル
 - 鋼球でタップをホールドするモデル
 - 焼き嵌めホルダー
 - ミスト加工用

ADC/FC/FCDなどの
脆い材質専用
1.5P...止まり穴用
3P...貫通穴専用

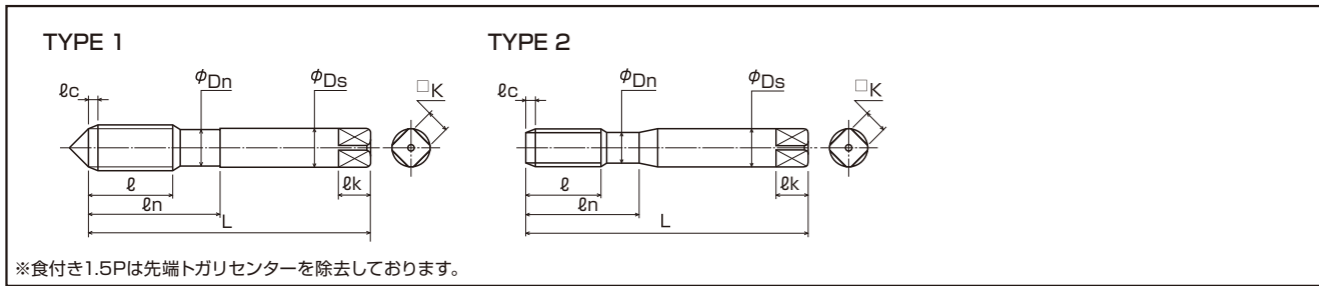

※食付き1.5Pは先端トガリセンターを除去しております。

●メートルねじ用 Metric

単位(Unit): mm

アイテム No. Item No.	呼び Nominal size	食付 ℓc	ZC溝数 ZC groove	精度 Limit	形状 Type	形状寸法 (mm) Dimensions						溝数 Flutes	
						L	ℓ	Ds	ℓn	Dn	K		ℓk
41162	M3 × 0.5	1.5P	1	GT5	1	100	11	4	18	2.4	3.2	6	3
41163	M3 × 0.5	3P	3	GT5	1	100	11	4	18	2.4	3.2	6	3
46220	M3 × 0.5	1.5P	1	GT5	1	70	11	4	18	2.4	3.2	6	3
46221	M3 × 0.5	3P	3	GT5	1	70	11	4	18	2.4	3.2	6	3
41164	M4 × 0.7	1.5P	1	GT6	1	100	13	5	20	3.1	4	7	3
41165	M4 × 0.7	3P	3	GT6	1	100	13	5	20	3.1	4	7	3
46222	M4 × 0.7	1.5P	1	GT6	1	70	13	5	20	3.1	4	7	3
46223	M4 × 0.7	3P	3	GT6	1	70	13	5	20	3.1	4	7	3
41166	M5 × 0.8	1.5P	1	GT6	2	100	16	5.5	25	4	4.5	7	3
41167	M5 × 0.8	3P	3	GT6	2	100	16	5.5	25	4	4.5	7	3
41168	M6 × 1	1.5P	1	GT6	2	100	19	6	30	4.8	4.5	7	3
41169	M6 × 1	3P	3	GT6	2	100	19	6	30	4.8	4.5	7	3
47879	M6 × 1	1.5P	1	GT6	2	120	19	6	35	4.8	4.5	7	3
47880	M6 × 1	3P	3	GT6	2	120	19	6	35	4.8	4.5	7	3
47881	M6 × 0.75	1.5P	1	GT6	2	100	19	6	30	4.8	4.5	7	3
47882	M6 × 0.75	3P	3	GT6	2	100	19	6	30	4.8	4.5	7	3
47883	M7 × 1	1.5P	1	GT6	2	100	22	7	40	5.8	5.5	8	3
47884	M7 × 1	3P	3	GT6	2	100	22	7	40	5.8	5.5	8	3
41170	M8 × 1.25	1.5P	1	GT6	2	100	22	8	40	6.2	6	9	3
41171	M8 × 1.25	3P	3	GT6	2	100	22	8	40	6.2	6	9	3
47885	M8 × 1.25	1.5P	1	GT6	2	120	22	8	50	6.2	6	9	3
47886	M8 × 1.25	3P	3	GT6	2	120	22	8	50	6.2	6	9	3
46845	M8 × 1	1.5P	1	GT6	2	100	22	8	40	6.2	6	9	3
46846	M8 × 1	3P	3	GT6	2	100	22	8	40	6.2	6	9	3
47887	M9 × 1.25	1.5P	2	GT6	2	100	24	8	39	7.2	6	9	4
47888	M9 × 1.25	3P	4	GT6	2	100	24	8	39	7.2	6	9	4
41172	M10 × 1.5	1.5P	2	GT7	2	100	24	8	39	7.8	6	9	4
41173	M10 × 1.5	3P	4	GT7	2	100	24	8	39	7.8	6	9	4
47889	M10 × 1.5	1.5P	2	GT7	2	120	24	8	50	7.8	6	9	4
47890	M10 × 1.5	3P	4	GT7	2	120	24	8	50	7.8	6	9	4
41174	M10 × 1.25	1.5P	2	GT6	2	100	24	8	39	7.8	6	9	4
41175	M10 × 1.25	3P	4	GT6	2	100	24	8	39	7.8	6	9	4
47891	M10 × 1.25	1.5P	2	GT6	2	120	24	8	50	7.8	6	9	4
47892	M10 × 1.25	3P	4	GT6	2	120	24	8	50	7.8	6	9	4
46847	M10 × 1	1.5P	2	GT6	2	100	24	8	39	7.8	6	9	4
46848	M10 × 1	3P	4	GT6	2	100	24	8	39	7.8	6	9	4
41176	M12 × 1.75	1.5P	2	GT7	2	100	29	10	43	9.8	8	11	4
41177	M12 × 1.75	3P	4	GT7	2	100	29	10	43	9.8	8	11	4
47893	M12 × 1.75	1.5P	2	GT7	2	120	29	10	60	9.8	8	11	4
47894	M12 × 1.75	3P	4	GT7	2	120	29	10	60	9.8	8	11	4
41178	M12 × 1.5	1.5P	2	GT7	2	100	29	10	43	9.8	8	11	4
41179	M12 × 1.5	3P	4	GT7	2	100	29	10	43	9.8	8	11	4
47895	M12 × 1.5	1.5P	2	GT7	2	120	29	10	60	9.8	8	11	4
47896	M12 × 1.5	3P	4	GT7	2	120	29	10	60	9.8	8	11	4
41180	M12 × 1.25	1.5P	2	GT7	2	100	29	10	43	9.8	8	11	4
41181	M12 × 1.25	3P	4	GT7	2	100	29	10	43	9.8	8	11	4
47897	M12 × 1.25	1.5P	2	GT7	2	120	29	10	60	9.8	8	11	4
47898	M12 × 1.25	3P	4	GT7	2	120	29	10	60	9.8	8	11	4
46849	M12 × 1	1.5P	2	GT7	2	100	29	10	43	9.8	8	11	4
46850	M12 × 1	3P	4	GT7	2	100	29	10	43	9.8	8	11	4

▶次頁へ続く Continued to next page

●メートルねじ用 Metric

単位(Unit): mm

アイテム No. Item No.	呼び Nominal size	食付 ℓc	ZC溝数 ZC groove	精度 Limit	形状 Type	形状寸法 (mm) Dimensions						溝数 Flutes	
						L	ℓ	Ds	ℓn	Dn	K		ℓk
46224	M14 × 2	1.5P	2	GT7	2	100	30	10.5	49	10.3	8	11	4
46225	M14 × 2	3P	4	GT7	2	100	30	10.5	49	10.3	8	11	4
47899	M14 × 2	1.5P	2	GT7	2	120	30	10.5	49	10.3	8	11	4
47900	M14 × 2	3P	4	GT7	2	120	30	10.5	49	10.3	8	11	4
46226	M14 × 1.5	1.5P	2	GT7	2	100	30	10.5	49	10.3	8	11	4
46227	M14 × 1.5	3P	4	GT7	2	100	30	10.5	49	10.3	8	11	4
47901	M14 × 1.5	1.5P	2	GT7	2	120	30	10.5	49	10.3	8	11	4
47902	M14 × 1.5	3P	4	GT7	2	120	30	10.5	49	10.3	8	11	4
46228	M16 × 2	1.5P	2	GT7	2	100	32	12.5	52	12.3	10	13	4
46229	M16 × 2	3P	4	GT7	2	100	32	12.5	52	12.3	10	13	4
47903	M16 × 2	1.5P	2	GT7	2	120	32	12.5	52	12.3	10	13	4
47904	M16 × 2	3P	4	GT7	2	120	32	12.5	52	12.3	10	13	4
46230	M16 × 1.5	1.5P	2	GT7	2	100	32	12.5	52	12.3	10	13	4
46231	M16 × 1.5	3P	4	GT7	2	100	32	12.5	52	12.3	10	13	4
47905	M16 × 1.5	1.5P	2	GT7	2	120	32	12.5	52	12.3	10	13	4
47906	M16 × 1.5	3P	4	GT7	2	120	32	12.5	52	12.3	10	13	4
46232	M18 × 2.5	1.5P	2	GT7	2	120	37	14	56	13.8	11	14	4
46233	M18 × 2.5	3P	4	GT7	2	120	37	14	56	13.8	11	14	4
47907	M18 × 2.5	1.5P	2	GT7	2	150	37	14	56	13.8	11	14	4
47908	M18 × 2.5	3P	4	GT7	2	150	37	14	56	13.8	11	14	4
46234	M18 × 1.5	1.5P	2	GT7	2	120	37	14	56	13.8	11	14	4
46235	M18 × 1.5	3P	4	GT7	2	120	37	14	56	13.8	11	14	4
47909	M18 × 1.5	1.5P	2	GT7	2	150	37	14	56	13.8	11	14	4
47910	M18 × 1.5	3P	4	GT7	2	150	37	14	56	13.8	11	14	4
46236	M20 × 2.5	1.5P	2	GT8	2	120	37	15	57	14.8	12	15	4
46237	M20 × 2.5	3P	4	GT8	2	120	37	15	57	14.8	12	15	4
47911	M20 × 2.5	1.5P	2	GT8	2	150	37	15	57	14.8	12	15	4
47912	M20 × 2.5	3P	4	GT8	2	150	37	15	57	14.8	12	15	4
46238	M20 × 1.5	1.5P	2	GT7	2	120	37	15	57	14.8	12	15	4
46239	M20 × 1.5	3P	4	GT7	2	120	37	15	57	14.8	12	15	4
47913	M20 × 1.5	1.5P	2	GT7	2	150	37	15	57	14.8	12	15	4
47914	M20 × 1.5	3P	4	GT7	2	150	37	15	57	14.8	12	15	4
46851	M22 × 2.5	1.5P	2	GT8	2	120	38	17	62	16.8	13	16	4
46852	M22 × 2.5	3P	4	GT8	2	120	38	17	62	16.8	13	16	4
47915	M22 × 2.5	1.5P	2	GT8	2	150	38	17	62	16.8	13	16	4
47916	M22 × 2.5	3P	4	GT8	2	150	38	17	62	16.8	13	16	4
46853	M22 × 1.5	1.5P	2	GT7	2	120	38	17	62	16.8	13	16	4
46854	M22 × 1.5	3P	4	GT7	2	120	38	17	62	16.8	13	16	4
47917	M22 × 1.5	1.5P	2	GT7	2	150	38	17	62	16.8	13	16	4
47918	M22 × 1.5	3P	4	GT7	2	150	38	17	62	16.8	13	16	4
46240	M24 × 3	1.5P	2	GT8	2	120	45	19	67	18.8	15	18	4
46241	M24 × 3	3P	4	GT8	2	120	45	19	67	18.8	15	18	4
47919	M24 × 3	1.5P	2	GT8	2	150	45	19	67	18.8	15	18	4
47920	M24 × 3	3P	4	GT8	2	150	45	19	67	18.8	15	18	4
46242	M24 × 1.5	1.5P	2	GT7	2	120	45	19	67	18.8	15	18	4
46243	M24 × 1.5	3P	4	GT7	2	120	45	19	67	18.8	15	18	4
47921	M24 × 1.5	1.5P	2	GT7	2	150	45	19	67	18.8	15	18	4
47922	M24 × 1.5	3P	4	GT7	2	150	45	19	67	18.8	15	18	4

※刃形状はADC/FC/FCD用に設定されております。
スチールやステンレスでの使用をご希望のお客様は、弊社までご相談ください。

※Blade shape has been set for the ADC / FC / FCD.
If you wish to use in steel and stainless steel, please contact us.

加工映像はコチラ



高速タッピングM3編



高速タッピングM6編

ADC/FC/FCD などの
脆い材質専用
1.5P...止まり穴用
3P...貫通穴専用

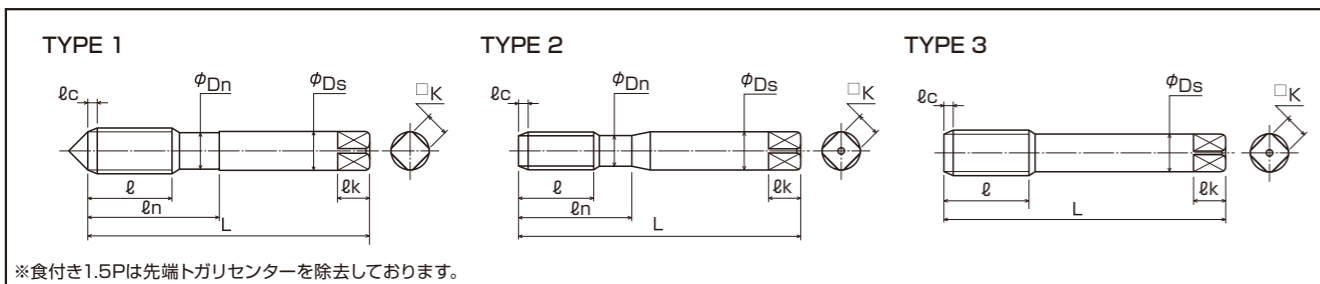

※食付き1.5Pは先端トガリセンターを除去しております。

●メートルねじ用 Metric

単位 (Unit) : mm

アイテム No. Item No.	呼び Nominal size	食付 ℓc	ZC溝数 ZC groove	精度 Limit	形状 Type	形状寸法 (mm) Dimensions							溝数 Flutes
						L	ℓ	Ds	ℓn	Dn	K	ℓk	
81600	M3 × 0.5	1.5P	1	GT5	1	100	11	4	18	2.4	3.2	6	3
81601	M3 × 0.5	3P	3	GT5	1	100	11	4	18	2.4	3.2	6	3
81636	M3 × 0.5	1.5P	1	GT5	1	70	11	4	18	2.4	3.2	6	3
81637	M3 × 0.5	3P	3	GT5	1	70	11	4	18	2.4	3.2	6	3
81602	M4 × 0.7	1.5P	1	GT6	1	100	13	5	20	3.1	4	7	3
81603	M4 × 0.7	3P	3	GT6	1	100	13	5	20	3.1	4	7	3
81638	M4 × 0.7	1.5P	1	GT6	1	70	13	5	20	3.1	4	7	3
81639	M4 × 0.7	3P	3	GT6	1	70	13	5	20	3.1	4	7	3
81604	M5 × 0.8	1.5P	1	GT6	2	100	16	5.5	25	4	4.5	7	3
81605	M5 × 0.8	3P	3	GT6	2	100	16	5.5	25	4	4.5	7	3
81606	M6 × 1	1.5P	1	GT6	2	100	19	6	30	4.8	4.5	7	3
81607	M6 × 1	3P	3	GT6	2	100	19	6	30	4.8	4.5	7	3
81608	M8 × 1.25	1.5P	1	GT6	2	100	22	8	40	6.2	6	9	3
81609	M8 × 1.25	3P	3	GT6	2	100	22	8	40	6.2	6	9	3
81852	M8 × 1	1.5P	1	GT6	2	100	22	8	40	6.2	6	9	3
81853	M8 × 1	3P	3	GT6	2	100	22	8	40	6.2	6	9	3
81610	M10 × 1.5	1.5P	2	GT7	2	100	24	8			6	9	4
81611	M10 × 1.5	3P	4	GT7	2	100	24	8			6	9	4
81612	M10 × 1.25	1.5P	2	GT6	2	100	24	8			6	9	4
81613	M10 × 1.25	3P	4	GT6	2	100	24	8			6	9	4
81854	M10 × 1	1.5P	2	GT6	2	100	24	8			6	9	4
81855	M10 × 1	3P	4	GT6	2	100	24	8			6	9	4
81614	M12 × 1.75	1.5P	2	GT7	2	100	29	10	43	9.8	8	11	4
81615	M12 × 1.75	3P	4	GT7	2	100	29	10	43	9.8	8	11	4
81616	M12 × 1.5	1.5P	2	GT7	2	100	29	10	43	9.8	8	11	4
81617	M12 × 1.5	3P	4	GT7	2	100	29	10	43	9.8	8	11	4
81618	M12 × 1.25	1.5P	2	GT7	2	100	29	10	43	9.8	8	11	4
81619	M12 × 1.25	3P	4	GT7	2	100	29	10	43	9.8	8	11	4
81856	M12 × 1	1.5P	2	GT7	2	100	29	10	43	9.8	8	11	4
81857	M12 × 1	3P	4	GT7	2	100	29	10	43	9.8	8	11	4

※刃形状はADC/FC/FCD用に設定されております。
 スチールやステンレスでの使用をご希望のお客様は、弊社までご相談ください。
 ※Blade shape has been set for the ADC / FC / FCD.
 If you wish to use in steel and stainless steel , please contact us.

新製品

FC/FCD などの
脆い材質専用
1.5P...止まり穴用
3P...貫通穴専用

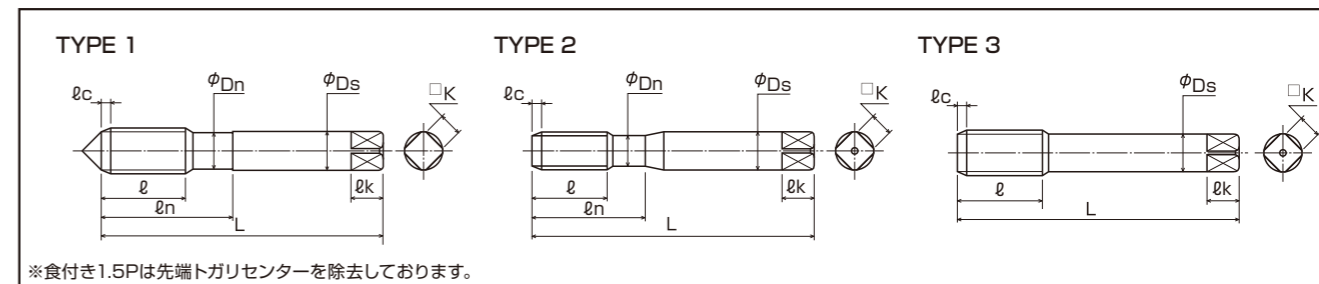

※食付き1.5Pは先端トガリセンターを除去しております。

●メートルねじ用 Metric

単位 (Unit) : mm

アイテム No. Item No.	呼び Nominal size	食付 ℓc	ZC溝数 ZC groove	精度 Limit	形状 Type	形状寸法 (mm) Dimensions							溝数 Flutes
						L	ℓ	Ds	ℓn	Dn	K	ℓk	
82193	M3 × 0.5	1.5P	1	GT5	1	100	11	4	18	2.4	3.2	6	3
82194	M3 × 0.5	3P	3	GT5	1	100	11	4	18	2.4	3.2	6	3
82195	M3 × 0.5	1.5P	1	GT5	1	70	11	4	18	2.4	3.2	6	3
82196	M3 × 0.5	3P	3	GT5	1	70	11	4	18	2.4	3.2	6	3
82197	M4 × 0.7	1.5P	1	GT6	1	100	13	5	20	3.1	4	7	3
82198	M4 × 0.7	3P	3	GT6	1	100	13	5	20	3.1	4	7	3
82199	M4 × 0.7	1.5P	1	GT6	1	70	13	5	20	3.1	4	7	3
82200	M4 × 0.7	3P	3	GT6	1	70	13	5	20	3.1	4	7	3
82201	M5 × 0.8	1.5P	1	GT6	2	100	16	5.5	25	4	4.5	7	3
82202	M5 × 0.8	3P	3	GT6	2	100	16	5.5	25	4	4.5	7	3
82203	M6 × 1	1.5P	1	GT6	2	100	19	6	30	4.8	4.5	7	3
82204	M6 × 1	3P	3	GT6	2	100	19	6	30	4.8	4.5	7	3
82205	M8 × 1.25	1.5P	2	GT8	2	100	22	8	40	6.2	6	9	4
82206	M8 × 1.25	3P	4	GT8	2	100	22	8	40	6.2	6	9	4
82207	M8 × 1	1.5P	2	GT8	2	100	22	8	40	6.2	6	9	4
82208	M8 × 1	3P	4	GT8	2	100	22	8	40	6.2	6	9	4
82209	M10 × 1.5	1.5P	2	GT8	3	100	24	8			6	9	4
82210	M10 × 1.5	3P	4	GT8	3	100	24	8			6	9	4
82211	M10 × 1.25	1.5P	2	GT8	3	100	24	8			6	9	4
82212	M10 × 1.25	3P	4	GT8	3	100	24	8			6	9	4
82213	M10 × 1	1.5P	2	GT8	3	100	24	8			6	9	4
82214	M10 × 1	3P	4	GT8	3	100	24	8			6	9	4
82215	M12 × 1.75	1.5P	2	GT8	2	100	29	10	43	9.8	8	11	4
82216	M12 × 1.75	3P	4	GT8	2	100	29	10	43	9.8	8	11	4
82217	M12 × 1.5	1.5P	2	GT8	2	100	29	10	43	9.8	8	11	4
82218	M12 × 1.5	3P	4	GT8	2	100	29	10	43	9.8	8	11	4
82219	M12 × 1.25	1.5P	2	GT8	2	100	29	10	43	9.8	8	11	4
82220	M12 × 1.25	3P	4	GT8	2	100	29	10	43	9.8	8	11	4
82221	M12 × 1	1.5P	2	GT8	2	100	29	10	43	9.8	8	11	4
82222	M12 × 1	3P	4	GT8	2	100	29	10	43	9.8	8	11	4

※刃形状はFC/FCD用に設定されております。
 スチールやステンレスでの使用をご希望のお客様は、弊社までご相談ください。
 ※Blade shape has been set for the FC / FCD.
 If you wish to use in steel and stainless steel , please contact us.



アルミダイカスト用
1.5P...止まり穴 / 貫通穴兼用

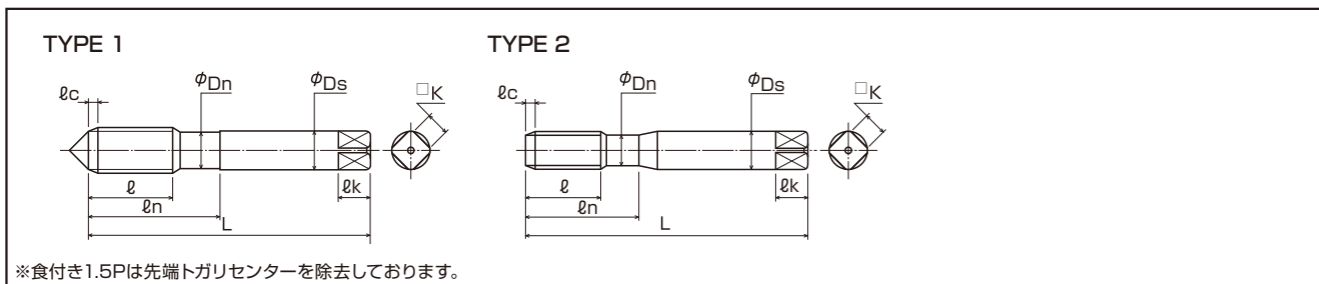

※食付き1.5Pは先端トガリセンターを除去しております。

●メートルねじ用 Metric

アイテム No. Item No.	呼び Nominal size	食付 l_c	ZC溝数 ZC groove	精度 Limit	形状 Type	形状寸法 (mm) Dimensions							溝数 Flutes
						L	l	D_s	l_n	D_n	K	l_k	
47923	M3 × 0.5	1.5P	1	GT5	1	100	11	4	18	2.4	3.2	6	3
47924	M3 × 0.5	1.5P	1	GT5	1	70	11	4	18	2.4	3.2	6	3
47925	M4 × 0.7	1.5P	1	GT6	1	100	13	5	20	3.1	4	7	3
47926	M4 × 0.7	1.5P	1	GT6	1	70	13	5	20	3.1	4	7	3
47927	M5 × 0.8	1.5P	1	GT6	2	100	16	5.5	25	4	4.5	7	3
47928	M6 × 1	1.5P	1	GT6	2	100	19	6	30	4.8	4.5	7	3
47929	M6 × 0.75	1.5P	1	GT6	2	100	19	6	30	4.8	4.5	7	3
47930	M7 × 1	1.5P	1	GT6	2	100	22	7	40	5.8	5.5	8	3
47931	M8 × 1.25	1.5P	2	GT6	2	100	22	8	40	6.2	6	9	4
47932	M8 × 1	1.5P	2	GT6	2	100	22	8	40	6.2	6	9	4
47933	M9 × 1.25	1.5P	2	GT6	2	100	24	8	39	7.2	6	9	4
47934	M10 × 1.5	1.5P	2	GT7	2	100	24	8	39	7.8	6	9	4
47935	M10 × 1.25	1.5P	2	GT6	2	100	24	8	39	7.8	6	9	4
47936	M10 × 1	1.5P	2	GT6	2	100	24	8	39	7.8	6	9	4
47937	M12 × 1.75	1.5P	2	GT7	2	100	29	10	43	9.8	8	11	4
47938	M12 × 1.5	1.5P	2	GT7	2	100	29	10	43	9.8	8	11	4
47939	M12 × 1.25	1.5P	2	GT7	2	100	29	10	43	9.8	8	11	4
47940	M12 × 1	1.5P	2	GT7	2	100	29	10	43	9.8	8	11	4



鋳抜き穴へ
ダイレクトタッピング!
1.5P...止まり穴用
3P...貫通穴専用

●メートルねじ用 Metric

アイテム No. Item No.	呼び Nominal size	食付 l_c	ZC溝数 ZC groove	精度 Limit	形状 Type	形状寸法 (mm) Dimensions							溝数 Flutes
						L	l	D_s	l_n	D_n	K	l_k	
46287	M3 × 0.5	1.5P	1	GT5	1	70	11	4	18	2.4	3.2	6	3
46288	M3 × 0.5	3P	3	GT5	1	70	11	4	18	2.4	3.2	6	3
46289	M4 × 0.7	1.5P	1	GT6	1	70	13	5	20	3.1	4	7	3
46290	M4 × 0.7	3P	3	GT6	1	70	13	5	20	3.1	4	7	3
46291	M5 × 0.8	1.5P	1	GT6	1	100	16	5.5	25	4	4.5	7	3
46292	M5 × 0.8	3P	3	GT6	1	100	16	5.5	25	4	4.5	7	3
46293	M6 × 1	1.5P	1	GT6	1	100	19	6	30	4.8	4.5	7	3
46294	M6 × 1	3P	3	GT6	1	100	19	6	30	4.8	4.5	7	3
46295	M8 × 1.25	1.5P	1	GT6	1	100	22	8	40	6.2	6	9	3
46296	M8 × 1.25	3P	3	GT6	1	100	22	8	40	6.2	6	9	3
46297	M10 × 1.5	1.5P	2	GT7	1	100	24	8	39	7.8	6	9	4
46298	M10 × 1.5	3P	4	GT7	1	100	24	8	39	7.8	6	9	4
46299	M10 × 1.25	1.5P	2	GT6	1	100	24	8	39	7.8	6	9	4
46300	M10 × 1.25	3P	4	GT6	1	100	24	8	39	7.8	6	9	4
46301	M12 × 1.75	1.5P	2	GT7	1	100	29	10	43	9.8	8	11	4
46302	M12 × 1.75	3P	4	GT7	1	100	29	10	43	9.8	8	11	4
46303	M12 × 1.5	1.5P	2	GT7	1	100	29	10	43	9.8	8	11	4
46304	M12 × 1.5	3P	4	GT7	1	100	29	10	43	9.8	8	11	4
46305	M12 × 1.25	1.5P	2	GT7	1	100	29	10	43	9.8	8	11	4
46306	M12 × 1.25	3P	4	GT7	1	100	29	10	43	9.8	8	11	4

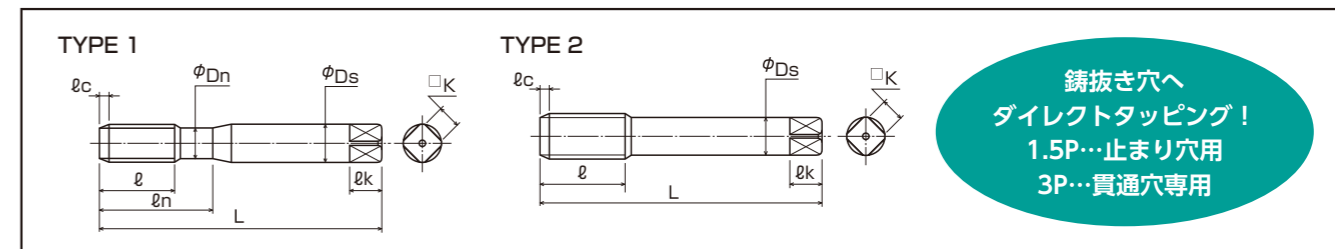

鋳抜き穴へ
ダイレクトタッピング!
1.5P...止まり穴用
3P...貫通穴専用

●メートルねじ用 Metric

アイテム No. Item No.	呼び Nominal size	食付 l_c	ZC溝数 ZC groove	精度 Limit	形状 Type	形状寸法 (mm) Dimensions							溝数 Flutes
						L	l	D_s	l_n	D_n	K	l_k	
81640	M3 × 0.5	1.5P	1	GT5	1	70	11	4	18	2.4	3.2	6	3
81641	M3 × 0.5	3P	3	GT5	1	70	11	4	18	2.4	3.2	6	3
81642	M4 × 0.7	1.5P	1	GT6	1	70	13	5	20	3.1	4	7	3
81643	M4 × 0.7	3P	3	GT6	1	70	13	5	20	3.1	4	7	3
81644	M5 × 0.8	1.5P	1	GT6	1	100	16	5.5	25	4	4.5	7	3
81645	M5 × 0.8	3P	3	GT6	1	100	16	5.5	25	4	4.5	7	3
81646	M6 × 1	1.5P	1	GT6	1	100	19	6	30	4.8	4.5	7	3
81647	M6 × 1	3P	3	GT6	1	100	19	6	30	4.8	4.5	7	3
81648	M8 × 1.25	1.5P	1	GT6	1	100	22	8	40	6.2	6	9	3
81649	M8 × 1.25	3P	3	GT6	1	100	22	8	40	6.2	6	9	3
81650	M10 × 1.5	1.5P	2	GT7	2	100	24	8	-	-	6	9	4
81651	M10 × 1.5	3P	4	GT7	2	100	24	8	-	-	6	9	4
81652	M10 × 1.25	1.5P	2	GT6	2	100	24	8	-	-	6	9	4
81653	M10 × 1.25	3P	4	GT6	2	100	24	8	-	-	6	9	4
81654	M12 × 1.75	1.5P	2	GT7	1	100	29	10	43	9.8	8	11	4
81655	M12 × 1.75	3P	4	GT7	1	100	29	10	43	9.8	8	11	4
81656	M12 × 1.5	1.5P	2	GT7	1	100	29	10	43	9.8	8	11	4
81657	M12 × 1.5	3P	4	GT7	1	100	29	10	43	9.8	8	11	4
81658	M12 × 1.25	1.5P	2	GT7	1	100	29	10	43	9.8	8	11	4
81659	M12 × 1.25	3P	4	GT7	1	100	29	10	43	9.8	8	11	4



PT 2.5P...貫通穴専用
PS/PF 1.5P...止まり穴用
PS/PF 3.5P...貫通穴専用

加工映像はコチラ

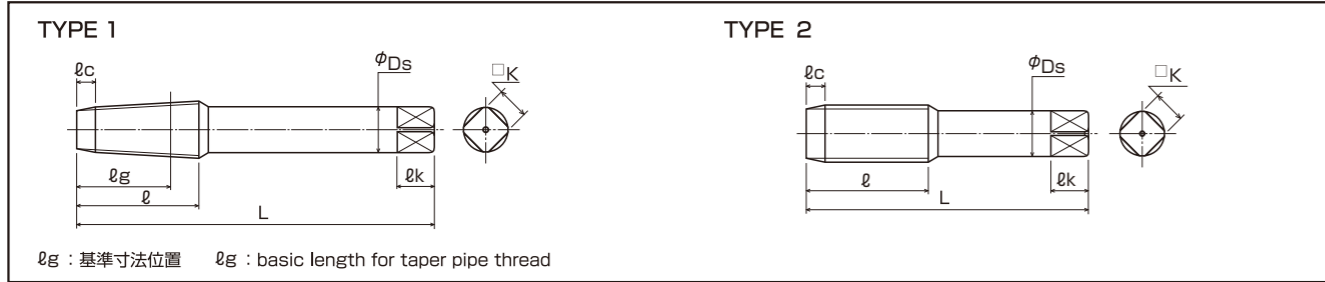

●管用ねじ用 Parallel / Taper Pipe Thread

アイテム No. Item No.	呼び Nominal size	食付 ℓc	ZC溝数 ZC groove	精度 Limit	形状 Type	形状寸法 (mm) Dimensions						溝数 Flutes	
						L	ℓ	Ds	ℓg	Dn	K		ℓk
18028	PT1/8-28	2.5P	4	JIS II	1	100	19	8	13		6	9	4
18029	PT1/4-19	2.5P	4	JIS II	1	100	28	11	21		9	12	4
18030	PT3/8-19	2.5P	4	JIS II	1	100	28	14	21		11	14	4
46284	PT1/2-14	2.5P	4	JIS II	1	100	35	18	25		14	17	4
18031	PS1/8-28	1.5P	2	JIS II	2	100	19	8			6	9	4
18032	PS1/8-28	3.5P	4	JIS II	2	100	19	8			6	9	4
18033	PS1/4-19	1.5P	2	JIS II	2	100	28	11			9	12	4
18034	PS1/4-19	3.5P	4	JIS II	2	100	28	11			9	12	4
18035	PS3/8-19	1.5P	2	JIS II	2	100	28	14			11	14	4
18036	PS3/8-19	3.5P	4	JIS II	2	100	28	14			11	14	4
46285	PS1/2-14	1.5P	2	JIS II	2	100	35	18			14	17	4
46286	PS1/2-14	3.5P	4	JIS II	2	100	35	18			14	17	4
46896	PF1/8-28	1.5P	2	JIS II	2	100	19	8			6	9	4
46897	PF1/8-28	3.5P	4	JIS II	2	100	19	8			6	9	4
46898	PF1/4-19	1.5P	2	JIS II	2	100	28	11			9	12	4
46899	PF1/4-19	3.5P	4	JIS II	2	100	28	11			9	12	4
46900	PF3/8-19	1.5P	2	JIS II	2	100	28	14			11	14	4
46901	PF3/8-19	3.5P	4	JIS II	2	100	28	14			11	14	4
46902	PF1/2-14	1.5P	2	JIS II	2	100	35	18			14	17	4
46903	PF1/2-14	3.5P	4	JIS II	2	100	35	18			14	17	4

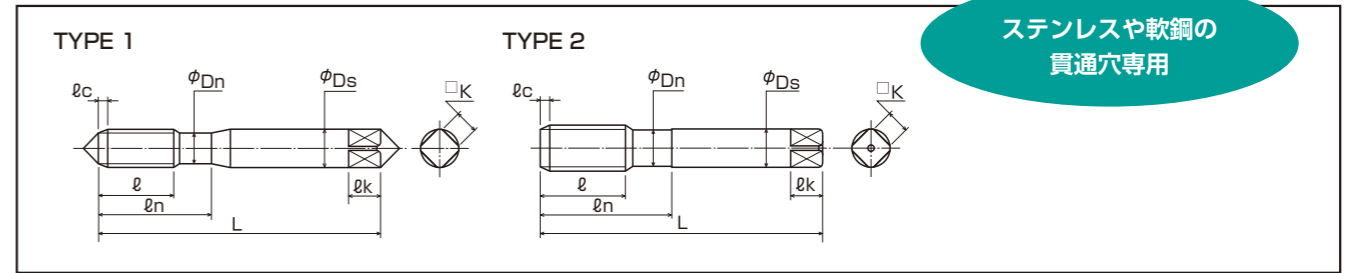

ステンレスや軟鋼の
貫通穴専用

●メートルねじ用 Metric

アイテム No. Item No.	呼び Nominal size	食付 ℓc	ZC溝数 ZC groove	精度 Limit	形状 Type	形状寸法 (mm) Dimensions						溝数 Flutes	
						L	ℓ	Ds	ℓn	Dn	K		ℓk
46855	M3 × 0.5	5P	3	GT5	1	70	11	4	18	2.4	3.2	6	3
46856	M4 × 0.7	5P	3	GT5	1	70	13	5	20	3.1	4	7	3
46857	M5 × 0.8	5P	3	GT6	1	100	16	5.5	25	4	4.5	7	3
46858	M6 × 1	5P	3	GT6	1	100	19	6	30	4.8	4.5	7	3
46859	M8 × 1.25	5P	3	GT6	1	100	22	8	40	6.2	6	9	3
47200	M8 × 1	5P	3	GT6	1	100	22	8	40	0	6	9	3
46860	M10 × 1.5	5P	3	GT7	1	100	24	8	39	7.8	6	9	3
46861	M10 × 1.25	5P	3	GT6	1	100	24	8	39	7.8	6	9	3
47201	M10 × 1	5P	3	GT6	1	100	24	8	39	0	6	9	3
46862	M12 × 1.75	5P	3	GT8	2	100	29	10	43	9.8	8	11	3
46863	M12 × 1.5	5P	3	GT7	2	100	29	10	43	9.8	8	11	3
46864	M12 × 1.25	5P	3	GT8	2	100	29	10	43	9.8	8	11	3
47202	M12 × 1	5P	3	GT7	2	100	29	10	43	0	8	11	3
46865	M14 × 2	5P	3	GT8	2	100	30	10.5	49	10.3	8	11	3
46866	M14 × 1.5	5P	3	GT7	2	100	30	10.5	49	10.3	8	11	3
46867	M16 × 2	5P	3	GT8	2	100	32	12.5	52	12.3	10	13	3
46868	M16 × 1.5	5P	3	GT7	2	100	32	12.5	52	12.3	10	13	3
46869	M18 × 2.5	5P	3	GT9	2	120	37	14	56	13.8	11	14	3
46870	M18 × 1.5	5P	3	GT8	2	120	37	14	56	13.8	11	14	3
46871	M20 × 2.5	5P	3	GT9	2	120	37	15	57	14.8	12	15	3
46872	M20 × 1.5	5P	3	GT8	2	120	37	15	57	14.8	12	15	3
47203	M22 × 2.5	5P	3	GT9	2	120	38	17	62	0	13	16	3
47204	M22 × 1.5	5P	3	GT8	2	120	38	17	62	0	13	16	3
46873	M24 × 3	5P	3	GT9	2	120	45	19	67	18.8	15	18	3
46874	M24 × 1.5	5P	3	GT8	2	120	45	19	67	18.8	15	18	3



高炭素鋼または
~ HRC35 の貫通穴専用



加工映像はコチラ

●メートルねじ用 Metric

アイテム No. Item No.	呼び Nominal size	食付 ℓc	ZC溝数 ZC groove	精度 Limit	形状 Type	形状寸法 (mm) Dimensions						溝数 Flutes	
						L	ℓ	Ds	ℓn	Dn	K		ℓk
46307	M6 × 1	5P	3	GT6	1	100	10	6	30	4.8	4.5	7	3
46308	M8 × 1.25	5P	3	GT7	1	100	15	8	40	6.2	6	9	3
46875	M8 × 1	5P	3	GT7	1	100	15	8	40	6.2	6	9	3
46309	M10 × 1.5	5P	3	GT7	1	100	18	8	39	7.8	6	9	3
46310	M10 × 1.25	5P	3	GT7	1	100	18	8	39	7.8	6	9	3
46876	M10 × 1	5P	3	GT7	1	100	18	8	39	7.8	6	9	3
46311	M12 × 1.75	5P	3	GT8	1	100	21	10	43	9.8	8	11	3
46312	M12 × 1.5	5P	3	GT8	1	100	21	10	43	9.8	8	11	3
46313	M12 × 1.25	5P	3	GT8	1	100	21	10	43	9.8	8	11	3
46877	M12 × 1	5P	3	GT8	1	100	21	10	43	9.8	8	11	3

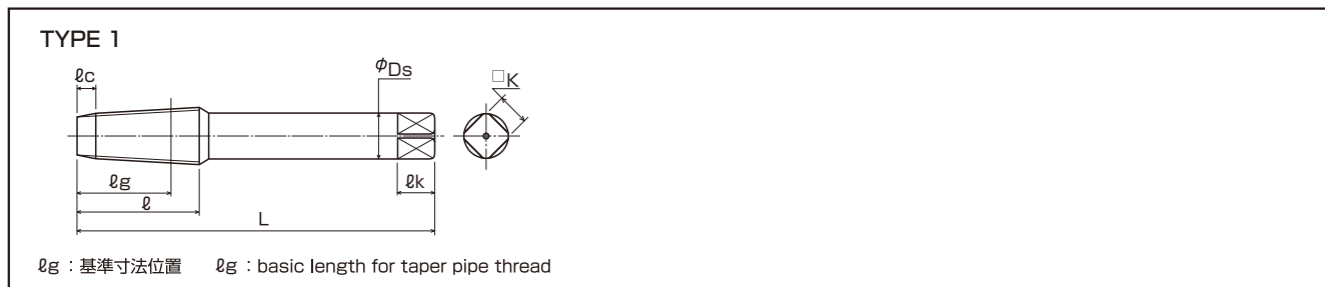

●管用ねじ用 Taper Pipe Thread · Short Thread

アイテム No. Item No.	呼び Nominal size	食付 ℓc	ZC溝数 ZC groove	精度 Limit	形状 Type	形状寸法 (mm) Dimensions						溝数 Flutes	
						L	ℓ	Ds	ℓg	Dn	K		ℓk
46904	PT1/8-28	2.5P	4	JIS II	1	100	16.5	8	10.5		6	9	4
46905	PT1/4-19	2.5P	4	JIS II	1	100	19.5	11	12.5		9	12	4
46906	PT3/8-19	2.5P	4	JIS II	1	100	21	14	14		11	14	4
46907	PT1/2-14	2.5P	4	JIS II	1	100	27	18	17		14	17	4



TYPE 1

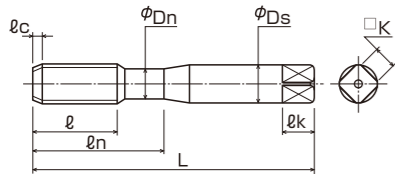

【食付き・精度表記について】
1.5P ... 1.5C+精度番号
例) 1.5Pで精度番号7番⇒1.5C7
4P ... P+精度番号
例) 4Pで精度番号5番⇒P5

※食付き1.5Pは先端トガリセンターを除去しております。

●メートルねじ用 Metric

単位(Unit): mm

アイテム No. Item No.	呼び Nominal size	食付 ℓc	ZC溝数 ZC groove	精度 Limit	形状 Type	形状寸法 (mm) Dimensions						溝数 Flutes	
						L	ℓ	Ds	ℓn	Dn	K		ℓk
18008	M3 × 0.5	1.5C	2	5	1	100	10	4	18	2.3	3.2	6	4
46244	M3 × 0.5	1.5C	2	6	1	100	10	4	18	2.3	3.2	6	4
46245	M3 × 0.5	1.5C	2	7	1	100	10	4	18	2.3	3.2	6	4
18009	M3 × 0.5	4P	2	5	1	100	10	4	18	2.3	3.2	6	4
46246	M3 × 0.5	4P	2	6	1	100	10	4	18	2.3	3.2	6	4
46247	M3 × 0.5	4P	2	7	1	100	10	4	18	2.3	3.2	6	4
18010	M4 × 0.7	1.5C	2	6	1	100	10	5	20	3	4	7	4
46248	M4 × 0.7	1.5C	2	7	1	100	10	5	20	3	4	7	4
46249	M4 × 0.7	1.5C	2	8	1	100	10	5	20	3	4	7	4
18011	M4 × 0.7	4P	2	6	1	100	10	5	20	3	4	7	4
46250	M4 × 0.7	4P	2	7	1	100	10	5	20	3	4	7	4
46251	M4 × 0.7	4P	2	8	1	100	10	5	20	3	4	7	4
18012	M5 × 0.8	1.5C	2	6	1	100	10	5.5	25	3.9	4.5	7	4
46252	M5 × 0.8	1.5C	2	7	1	100	10	5.5	25	3.9	4.5	7	4
46253	M5 × 0.8	1.5C	2	8	1	100	10	5.5	25	3.9	4.5	7	4
18013	M5 × 0.8	4P	2	6	1	100	10	5.5	25	3.9	4.5	7	4
46254	M5 × 0.8	4P	2	7	1	100	10	5.5	25	3.9	4.5	7	4
46255	M5 × 0.8	4P	2	8	1	100	10	5.5	25	3.9	4.5	7	4
18014	M6 × 1	1.5C	2	7	1	100	10	6	30	4.6	4.5	7	4
46256	M6 × 1	1.5C	2	8	1	100	10	6	30	4.6	4.5	7	4
46257	M6 × 1	1.5C	2	9	1	100	10	6	30	4.6	4.5	7	4
18015	M6 × 1	4P	2	7	1	100	10	6	30	4.6	4.5	7	4
46258	M6 × 1	4P	2	8	1	100	10	6	30	4.6	4.5	7	4
46259	M6 × 1	4P	2	9	1	100	10	6	30	4.6	4.5	7	4
47950	M6 × 0.75	1.5C	2	7	1	100	10	6	30	4.6	4.5	7	4
47951	M6 × 0.75	1.5C	2	8	1	100	10	6	30	4.6	4.5	7	4
47952	M6 × 0.75	1.5C	2	9	1	100	10	6	30	4.6	4.5	7	4
47953	M6 × 0.75	4P	2	7	1	100	10	6	30	4.6	4.5	7	4
47954	M6 × 0.75	4P	2	8	1	100	10	6	30	4.6	4.5	7	4
47955	M6 × 0.75	4P	2	9	1	100	10	6	30	4.6	4.5	7	4
47956	M7 × 1	1.5C	3	7	1	100	16	7	40	5.6	5.5	8	6
47957	M7 × 1	1.5C	3	8	1	100	16	7	40	5.6	5.5	8	6
47958	M7 × 1	1.5C	3	9	1	100	16	7	40	5.6	5.5	8	6
47959	M7 × 1	4P	3	7	1	100	16	7	40	5.6	5.5	8	6
47960	M7 × 1	4P	3	8	1	100	16	7	40	5.6	5.5	8	6
47961	M7 × 1	4P	3	9	1	100	16	7	40	5.6	5.5	8	6
18016	M8 × 1.25	1.5C	3	7	1	100	18	8	40	6.2	6	9	6
46260	M8 × 1.25	1.5C	3	8	1	100	18	8	40	6.2	6	9	6
46261	M8 × 1.25	1.5C	3	9	1	100	18	8	40	6.2	6	9	6
18017	M8 × 1.25	4P	3	7	1	100	18	8	40	6.2	6	9	6
46262	M8 × 1.25	4P	3	8	1	100	18	8	40	6.2	6	9	6
46263	M8 × 1.25	4P	3	9	1	100	18	8	40	6.2	6	9	6
46878	M8 × 1	1.5C	3	7	1	100	18	8	40	6.2	6	9	6
46879	M8 × 1	1.5C	3	8	1	100	18	8	40	6.2	6	9	6
46880	M8 × 1	1.5C	3	9	1	100	18	8	40	6.2	6	9	6
46881	M8 × 1	4P	3	7	1	100	18	8	40	6.2	6	9	6
46882	M8 × 1	4P	3	8	1	100	18	8	40	6.2	6	9	6
46883	M8 × 1	4P	3	9	1	100	18	8	40	6.2	6	9	6

▶次頁へ続く Continued to next page

●メートルねじ用 Metric

単位(Unit): mm

アイテム No. Item No.	呼び Nominal size	食付 ℓc	ZC溝数 ZC groove	精度 Limit	形状 Type	形状寸法 (mm) Dimensions						溝数 Flutes	
						L	ℓ	Ds	ℓn	Dn	K		ℓk
18018	M10 × 1.5	1.5C	4	7	1	100	19	8	39	7.8	6	9	8
46264	M10 × 1.5	1.5C	4	8	1	100	19	8	39	7.8	6	9	8
46265	M10 × 1.5	1.5C	4	9	1	100	19	8	39	7.8	6	9	8
18019	M10 × 1.5	4P	4	7	1	100	19	8	39	7.8	6	9	8
46266	M10 × 1.5	4P	4	8	1	100	19	8	39	7.8	6	9	8
46267	M10 × 1.5	4P	4	9	1	100	19	8	39	7.8	6	9	8
18020	M10 × 1.25	1.5C	4	7	1	100	19	8	39	7.8	6	9	8
46268	M10 × 1.25	1.5C	4	8	1	100	19	8	39	7.8	6	9	8
46269	M10 × 1.25	1.5C	4	9	1	100	19	8	39	7.8	6	9	8
18021	M10 × 1.25	4P	4	7	1	100	19	8	39	7.8	6	9	8
46270	M10 × 1.25	4P	4	8	1	100	19	8	39	7.8	6	9	8
46271	M10 × 1.25	4P	4	9	1	100	19	8	39	7.8	6	9	8
46884	M10 × 1	1.5C	4	7	1	100	19	8	39	7.8	6	9	8
46885	M10 × 1	1.5C	4	8	1	100	19	8	39	7.8	6	9	8
46886	M10 × 1	1.5C	4	9	1	100	19	8	39	7.8	6	9	8
46887	M10 × 1	4P	4	7	1	100	19	8	39	7.8	6	9	8
46888	M10 × 1	4P	4	8	1	100	19	8	39	7.8	6	9	8
46889	M10 × 1	4P	4	9	1	100	19	8	39	7.8	6	9	8
46272	M12 × 1.75	1.5C	4	8	1	100	19	10	43	9.8	8	11	8
18022	M12 × 1.75	1.5C	4	10	1	100	19	10	43	9.8	8	11	8
46273	M12 × 1.75	1.5C	4	12	1	100	19	10	43	9.8	8	11	8
46274	M12 × 1.75	4P	4	8	1	100	19	10	43	9.8	8	11	8
18023	M12 × 1.75	4P	4	10	1	100	19	10	43	9.8	8	11	8
46275	M12 × 1.75	4P	4	12	1	100	19	10	43	9.8	8	11	8
46276	M12 × 1.5	1.5C	4	8	1	100	19	10	43	9.8	8	11	8
18024	M12 × 1.5	1.5C	4	10	1	100	19	10	43	9.8	8	11	8
46277	M12 × 1.5	1.5C	4	12	1	100	19	10	43	9.8	8	11	8
46278	M12 × 1.5	4P	4	8	1	100	19	10	43	9.8	8	11	8
18025	M12 × 1.5	4P	4	10	1	100	19	10	43	9.8	8	11	8
46279	M12 × 1.5	4P	4	12	1	100	19	10	43	9.8	8	11	8
46280	M12 × 1.25	1.5C	4	8	1	100	19	10	43	9.8	8	11	8
46281	M12 × 1.25	1.5C	4	10	1	100	19	10	43	9.8	8	11	8
18026	M12 × 1.25	1.5C	4	12	1	100	19	10	43	9.8	8	11	8
46282	M12 × 1.25	4P	4	8	1	100	19	10	43	9.8	8	11	8
46283	M12 × 1.25	4P	4	10	1	100	19	10	43	9.8	8	11	8
18027	M12 × 1.25	4P	4	12	1	100	19	10	43	9.8	8	11	8
46890	M12 × 1	1.5C	4	7	1	100	19	10	43	9.8	8	11	8
46891	M12 × 1	1.5C	4	9	1	100	19	10	43	9.8	8	11	8
46892	M12 × 1	1.5C	4	11	1	100	19	10	43	9.8	8	11	8
46893	M12 × 1	4P	4	7	1	100	19	10	43	9.8	8	11	8
46894	M12 × 1	4P	4	9	1	100	19	10	43	9.8	8	11	8
46895	M12 × 1	4P	4	11	1	100	19	10	43	9.8	8	11	8

・精度欄の■は2級めねじ相当適応の推奨精度です。

・The recommended tap limit in ■ corresponds to JIS Class 2 internal thread standard.



加工映像はコチラ

新製品



滑らかな表面と新設計のラジアル形状により、加工トルク低減や耐久性を向上させた盛り上げタップです。
A forming tap whose tapping torque is reduced and durability is improved by a smooth surface and new design of radial form.

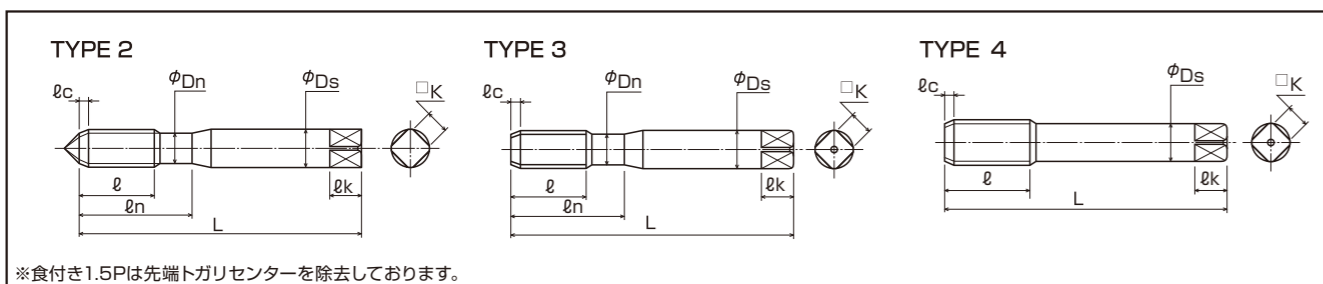

※食付き1.5Pは先端トガリセンターを除去しております。

●メートルねじ用 Metric

単位 (Unit) : mm

アイテム No. Item No.	呼び Nominal size	食付 Dc	ZC溝数 ZC groove	精度 Limit	形状 Type	形状 寸法 (mm)						ラジアル数 Radial	油溝数 Oil groove	新モデル New Model	
						L	ℓ	Ds	ℓn	Dn	K				ℓk
82254	M3 ×0.5	1.5P	2	5	2	70	10	4	18	2.4	3.2	6	4	4	★
82255	M4 ×0.7	1.5P	2	6	2	70	10	5	20	3.1	4	7	4	4	★
82256	M5 ×0.8	1.5P	2	6	3	100	10	5.5	25	4	4.5	7	4	4	★
82257	M6 ×1	1.5P	2	7	3	100	10	6	30	4.6	4.5	7	5	5	★
82258	M8 ×1.25	1.5P	3	7	3	100	18	8	40	6.2	6	9	6	6	★
82259	M8 ×1	1.5P	3	7	3	100	18	8	40	6.2	6	9	6	6	★
82260	M10 ×1.5	1.5P	4	7	4	100	19	8	-	-	6	9	8	8	★
82261	M10 ×1.25	1.5P	4	7	4	100	19	8	-	-	6	9	8	8	★
82262	M10 ×1	1.5P	4	7	4	100	19	8	-	-	6	9	8	8	★
82263	M12 ×1.75	1.5P	4	10	3	100	23	10	43	9.8	8	11	8	8	★
82264	M12 ×1.5	1.5P	4	10	3	100	23	10	43	9.8	8	11	8	8	★
82265	M12 ×1.25	1.5P	4	12	3	100	23	10	43	9.8	8	11	8	8	★
82266	M12 ×1	1.5P	4	9	3	100	23	10	43	9.8	8	11	8	8	★

・精度欄の は2級めねじ相当適応の推奨精度です。 ・ The recommended tap limit in corresponds to JIS Class 2 internal thread standard.
・★の新モデルは2022年秋発売予定。 ・ New model of ★ will be released in the fall of 2022.

新しい内部給油のカタチ

シャンク部にサイドスルー溝を設けた新構造

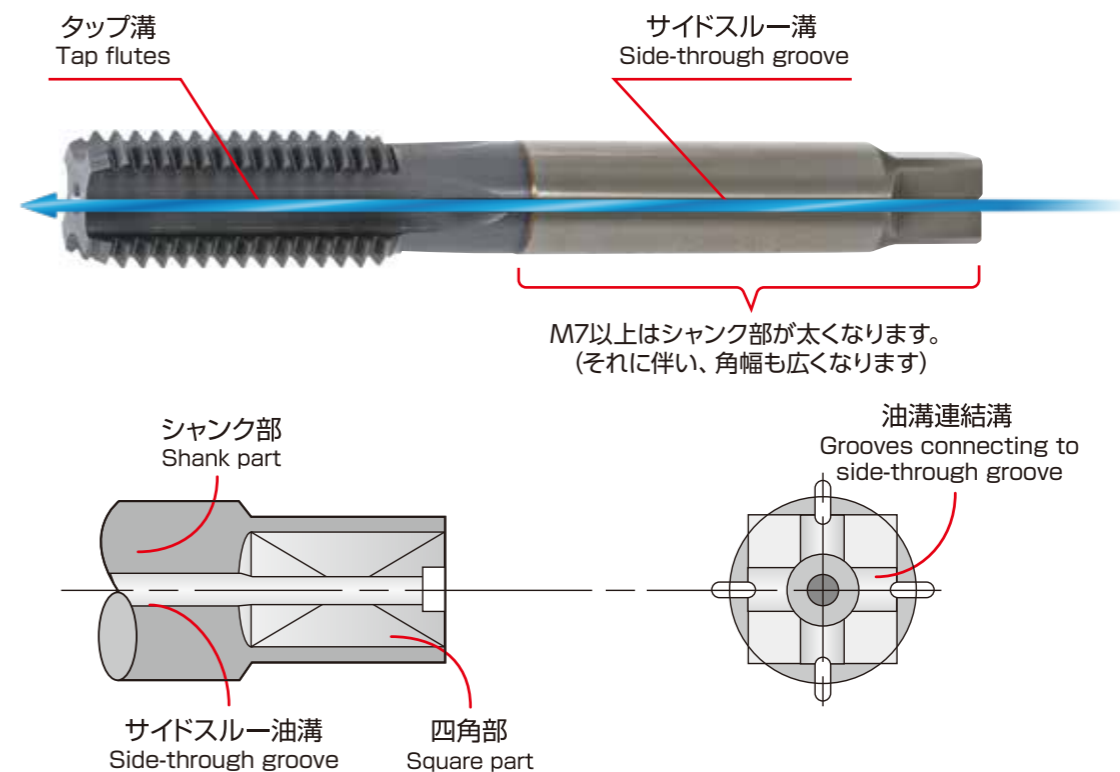

今までの内部給油仕様での問題点

横穴OH(オイルホール)の場合

加工開始時にドライに近い
穴が細く、吐出量が少ない
切り粉の排出効果が低い
止まり穴では排出を阻害
横穴が多く、高価
先端落としでの再研回数が少ない



隙間からの吐出の場合

止まり穴で使用できない
拡散量が多く、下穴への流入量が少ない
ロングシャンクでは効果が下がってしまう
シャンク径より下穴径が小さい
M7以下では効果が期待できない
標準品を使用できる



ZCシリーズの場合

十分な給油が可能
加工開始時より切り粉を強力に排出
吐出量が多い
溝追加のみで安価



ZC-SL-TFで通/止兼用

止まり穴では切り粉を残しにくい
貫通穴でも内部給油効果を落とさない



サイドスルー溝位置 (M7~)



サイドスルー溝位置 (~M6)

→ ...ゼロチップタップシリーズ
サイドスルー溝位置 (通/止兼用)

貫通穴で効果が低い (横穴仕様であっても)
アルミ加工ではOHが詰まってしまう
工具単価が高い

貫通穴でも高い効果を発揮できる
冷却・潤滑効果が高く、加工速度を上げられる
工具単価を抑えやすい

下穴径について Hole Sizes

- ・めねじ内径寸法を一定にしたい場合は、下穴径表のひっかけ率推奨の90%~95%を参考にしてください。(シームが多少残ります。)
- ・SUSや加工後の収縮が著しい材質は大きめの下穴径を参考にしてください。
- ・めねじ内径部のシームを完全切除したい場合は、ご相談ください。

- ・To keep the minor diameter of the internal thread constant, refer to the 90% to 95% recommended catching rate in the prepared hole diameter table.
- ・For SUS and materials that shrink significantly after processing, refer to the large pilot hole diameter.
- ・Please contact us if you want to completely remove the seam on the minor diameter of the internal thread.

シームレスタフレットの下穴径表
Hole Size for Seamless TAFLET

呼び Nominal size	ピッチ Pitch	サイドエンドミル刃 End mill diameter	標準精度番号 Standard tap limit number	ひっかけ率(%)別下穴径(mm) Hole diameter (mm) by percentage of thread engagement (%)			
				105%	100%	95%	90%
M2	0.4	φ 1.62	4	1.76	1.77	1.78	1.80
M2.3	0.4	φ 1.92	4	2.06	2.07	2.08	2.09
M2.5	0.45	φ 2.07	4	2.23	2.24	2.26	2.27
M2.6	0.45	φ 2.17	4	2.33	2.34	2.36	2.37
M3	0.5	φ 2.53	5	2.70	2.72	2.73	2.74
M3.5	0.6	φ 2.93	5	3.14	3.16	3.18	3.19
M4	0.7	φ 3.34	6	3.58	3.60	3.62	3.64
M5	0.8	φ 4.24	6	4.52	4.55	4.57	4.59
M6	0.75	φ 5.29	6	5.55	5.57	5.59	5.61
	1	φ 5.05	7	5.40	5.43	5.46	5.49
M7	1	φ 6.05	7	6.40	6.43	6.46	6.49
M8	0.75	φ 7.29	7	7.55	7.57	7.59	7.61
	1	φ 7.05	7	7.40	7.43	7.46	7.49
	1.25	φ 6.82	7	7.26	7.29	7.33	7.36
M9	1.25	φ 7.82	7	8.26	8.29	8.33	8.36
	1	φ 9.05	7	9.40	9.43	9.46	9.49
M10	1.25	φ 8.82	7	9.26	9.29	9.33	9.36
	1.5	φ 8.58	7	9.11	9.15	9.19	9.23
	1	φ 10.05	9	10.42	10.45	10.47	10.50
M11	1.5	φ 9.58	10	10.11	10.15	10.19	10.23
	1	φ 11.05	9	11.42	11.45	11.47	11.50
	1.25	φ 10.82	12	11.31	11.34	11.38	11.41
M12	1.5	φ 10.58	10	11.13	11.17	11.22	11.26
	1.75	φ 10.34	10	10.98	11.03	11.08	11.13
	1.5	φ 12.58	10	13.12	13.16	13.20	13.25
M14	2	φ 12.11	11	12.81	12.86	12.92	12.97
	1.5	φ 14.58	10	15.12	15.16	15.20	15.25
M16	2	φ 14.11	11	14.81	14.86	14.92	14.97
	1	φ 17.05	10	17.42	17.45	17.47	17.50
M18	1.5	φ 16.58	11	17.12	17.16	17.20	17.25
	2.5	φ 15.63	12	16.51	16.58	16.65	16.72
	1.5	φ 18.58	11	19.12	19.16	19.20	19.25
M20	2.5	φ 17.63	12	18.51	18.58	18.65	18.72



TYPE 1

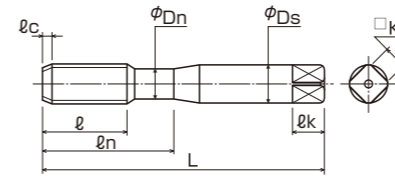

【食付き・精度表記について】
1.5P...1.5C+精度番号
例) 1.5Pで精度番号7番⇒1.5C7

※食付き1.5Pは先端トガリセンターを除去しております。

●メートルねじ用 Metric

単位(Unit): mm

アイテム No. Item No.	呼び Nominal size	食付 ℓc	ZC溝数 ZC groove	精度 Limit	形状 Type	形状寸法 (mm) Dimensions							溝数 Flutes
						L	ℓ	Ds	ℓn	Dn	K	ℓk	
18058	M3 × 0.5	1.5P	1	5	1	100	10	4	18	2.3	3.2	6	4
46338	M3 × 0.5	1.5P	1	6	1	100	10	4	18	2.3	3.2	6	4
46339	M3 × 0.5	1.5P	1	7	1	100	10	4	18	2.3	3.2	6	4
18059	M4 × 0.7	1.5P	1	6	1	100	10	5	20	3	4	7	4
46340	M4 × 0.7	1.5P	1	7	1	100	10	5	20	3	4	7	4
46341	M4 × 0.7	1.5P	1	8	1	100	10	5	20	3	4	7	4
18060	M5 × 0.8	1.5P	1	6	1	100	10	5.5	25	3.9	4.5	7	4
46342	M5 × 0.8	1.5P	1	7	1	100	10	5.5	25	3.9	4.5	7	4
46343	M5 × 0.8	1.5P	1	8	1	100	10	5.5	25	3.9	4.5	7	4
18061	M6 × 1	1.5P	1	7	1	100	10	6	30	4.6	4.5	7	4
46344	M6 × 1	1.5P	1	8	1	100	10	6	30	4.6	4.5	7	4
46345	M6 × 1	1.5P	1	9	1	100	10	6	30	4.6	4.5	7	4
47941	M6 × 0.75	1.5P	1	7	1	100	10	6	30	4.6	4.5	7	4
47942	M6 × 0.75	1.5P	1	8	1	100	10	6	30	4.6	4.5	7	4
47943	M6 × 0.75	1.5P	1	9	1	100	10	6	30	4.6	4.5	7	4
47944	M7 × 1	1.5P	2	7	1	100	16	7	40	5.6	5.5	8	6
47945	M7 × 1	1.5P	2	8	1	100	16	7	40	5.6	5.5	8	6
47946	M7 × 1	1.5P	2	9	1	100	16	7	40	5.6	5.5	8	6
18063	M8 × 1.25	1.5P	2	7	1	100	18	8	40	6.2	6	9	6
46346	M8 × 1.25	1.5P	2	8	1	100	18	8	40	6.2	6	9	6
46347	M8 × 1.25	1.5P	2	9	1	100	18	8	40	6.2	6	9	6
46911	M8 × 1	1.5P	2	7	1	100	18	8	40	6.2	6	9	6
46912	M8 × 1	1.5P	2	8	1	100	18	8	40	6.2	6	9	6
46913	M8 × 1	1.5P	2	9	1	100	18	8	40	6.2	6	9	6
47947	M9 × 1.25	1.5P	2	7	1	100	18	8	39	7.2	6	9	6
47948	M9 × 1.25	1.5P	2	8	1	100	18	8	39	7.2	6	9	6
47949	M9 × 1.25	1.5P	2	9	1	100	18	8	39	7.2	6	9	6
18064	M10 × 1.5	1.5P	2	7	1	100	19	8	39	7.8	6	9	6
46348	M10 × 1.5	1.5P	2	8	1	100	19	8	39	7.8	6	9	6
46349	M10 × 1.5	1.5P	2	9	1	100	19	8	39	7.8	6	9	6
18065	M10 × 1.25	1.5P	2	7	1	100	19	8	39	7.8	6	9	6
46350	M10 × 1.25	1.5P	2	8	1	100	19	8	39	7.8	6	9	6
46351	M10 × 1.25	1.5P	2	9	1	100	19	8	39	7.8	6	9	6
18066	M10 × 1	1.5P	2	7	1	100	19	8	39	7.8	6	9	6
46352	M10 × 1	1.5P	2	8	1	100	19	8	39	7.8	6	9	6
46353	M10 × 1	1.5P	2	9	1	100	19	8	39	7.8	6	9	6
46354	M12 × 1.75	1.5P	2	8	1	100	19	10	43	9.8	8	11	6
18067	M12 × 1.75	1.5P	2	10	1	100	19	10	43	9.8	8	11	6
46355	M12 × 1.75	1.5P	2	12	1	100	19	10	43	9.8	8	11	6
46356	M12 × 1.5	1.5P	2	8	1	100	19	10	43	9.8	8	11	6
18068	M12 × 1.5	1.5P	2	10	1	100	19	10	43	9.8	8	11	6
46357	M12 × 1.5	1.5P	2	12	1	100	19	10	43	9.8	8	11	6
46358	M12 × 1.25	1.5P	2	8	1	100	19	10	43	9.8	8	11	6
46359	M12 × 1.25	1.5P	2	10	1	100	19	10	43	9.8	8	11	6
18069	M12 × 1.25	1.5P	2	12	1	100	19	10	43	9.8	8	11	6
46914	M12 × 1	1.5P	2	7	1	100	19	10	43	9.8	8	11	6
46915	M12 × 1	1.5P	2	9	1	100	19	10	43	9.8	8	11	6
46916	M12 × 1	1.5P	2	11	1	100	19	10	43	9.8	8	11	6

・精度欄の■は2級めねじ相当適応の推奨精度です。

・The recommended tap limit in ■ corresponds to JIS Class 2 internal thread standard.

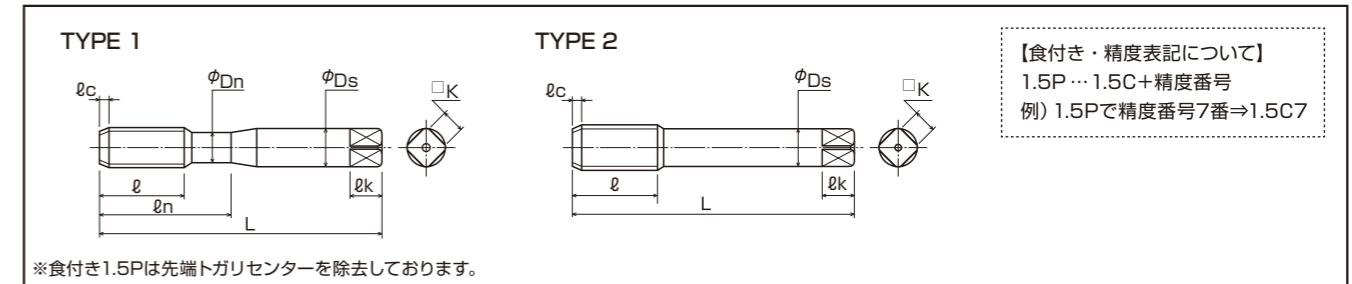

Coming Soon

●メートルねじ用 Metric

単位 (Unit) : mm

アイテム No. Item No.	呼び Nominal size	食付 ℓ_c	ZC溝数 ZC groove	精度 Limit	形状 Type	形状寸法 (mm) Dimensions							溝数 Flutes
						L	ℓ	D_s	ℓ_n	D_n	K	ℓ_k	
81628	M3 × 0.5	1.5P	1	5	1	70	10	4	18	2.4	3.2	6	4
81676	M3 × 0.5	1.5P	1	6	1	70	10	4	18	2.4	3.2	6	4
81677	M3 × 0.5	1.5P	1	7	1	70	10	4	18	2.4	3.2	6	4
81629	M4 × 0.7	1.5P	1	6	1	70	10	5	20	3.1	4	7	4
81678	M4 × 0.7	1.5P	1	7	1	70	10	5	20	3.1	4	7	4
81679	M4 × 0.7	1.5P	1	8	1	70	10	5	20	3.1	4	7	4
81630	M5 × 0.8	1.5P	1	6	1	100	10	5.5	25	4	4.5	7	4
81680	M5 × 0.8	1.5P	1	7	1	100	10	5.5	25	4	4.5	7	4
81681	M5 × 0.8	1.5P	1	8	1	100	10	5.5	25	4	4.5	7	4
81631	M6 × 1	1.5P	1	7	1	100	10	6	30	4.6	4.5	7	4
81682	M6 × 1	1.5P	1	8	1	100	10	6	30	4.6	4.5	7	4
81683	M6 × 1	1.5P	1	9	1	100	10	6	30	4.6	4.5	7	4
81632	M8 × 1.25	1.5P	2	7	1	100	18	8	40	6.2	6	9	6
81684	M8 × 1.25	1.5P	2	8	1	100	18	8	40	6.2	6	9	6
81685	M8 × 1.25	1.5P	2	9	1	100	18	8	40	6.2	6	9	6
81861	M8 × 1	1.5P	2	7	1	100	18	8	40	6.2	6	9	6
81862	M8 × 1	1.5P	2	8	1	100	18	8	40	6.2	6	9	6
81863	M8 × 1	1.5P	2	9	1	100	18	8	40	6.2	6	9	6
81633	M10 × 1.5	1.5P	2	7	2	100	19	8	—	—	6	9	6
81686	M10 × 1.5	1.5P	2	8	2	100	19	8	—	—	6	9	6
81687	M10 × 1.5	1.5P	2	9	2	100	19	8	—	—	6	9	6
81634	M10 × 1.25	1.5P	2	7	2	100	19	8	—	—	6	9	6
81688	M10 × 1.25	1.5P	2	8	2	100	19	8	—	—	6	9	6
81689	M10 × 1.25	1.5P	2	9	2	100	19	8	—	—	6	9	6
81635	M10 × 1	1.5P	2	7	2	100	19	8	—	—	6	9	6
81690	M10 × 1	1.5P	2	8	2	100	19	8	—	—	6	9	6
81691	M10 × 1	1.5P	2	9	2	100	19	8	—	—	6	9	6

- ・精度欄の ■ は2級めねじ相当適応の推奨精度です。
- ・ The recommended tap limit in ■ corresponds to JIS Class 2 internal thread standard.



加工映像はコチラ